

NOTES:  
1. TORQUE SCREWS TO ATTACH MODEL 5968 BRACKET TO GEARMOTOR WITH 30 LB-IN

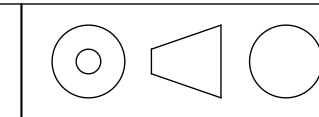

DESCRIPTION: GEARMOTOR 24A2FEPM-D3/4/5 WITH L BRACKET	
SHEET: 1/1	UNLESS OTHERWISE SPECIFIED:
SCALE: 1:1	UNITS ARE IN INCHES [mm]
C	TOLERANCES: .XX:±.01 .XXX:±.005 ANGLES: X°:±3° X.X°:±0.5°

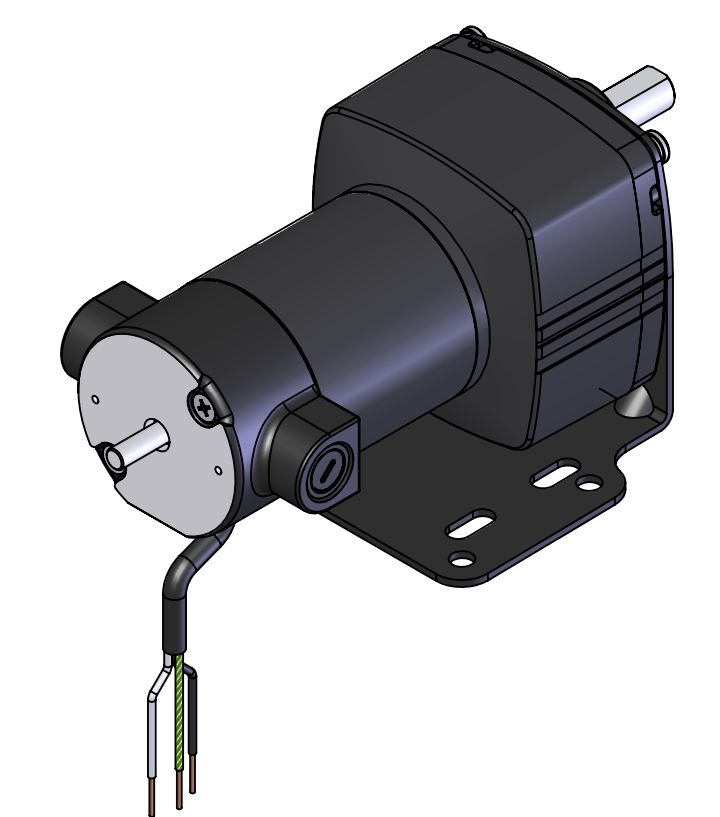
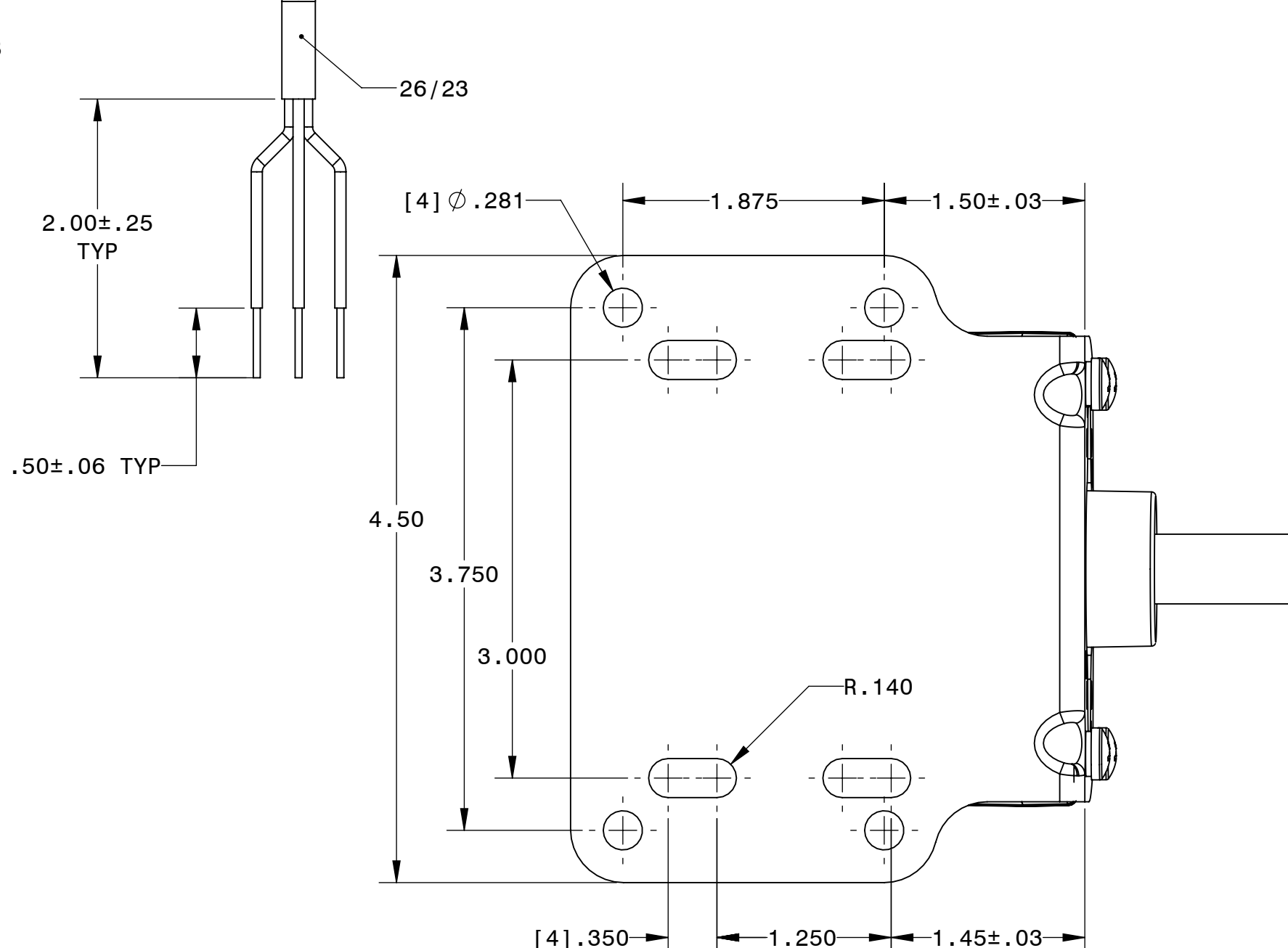
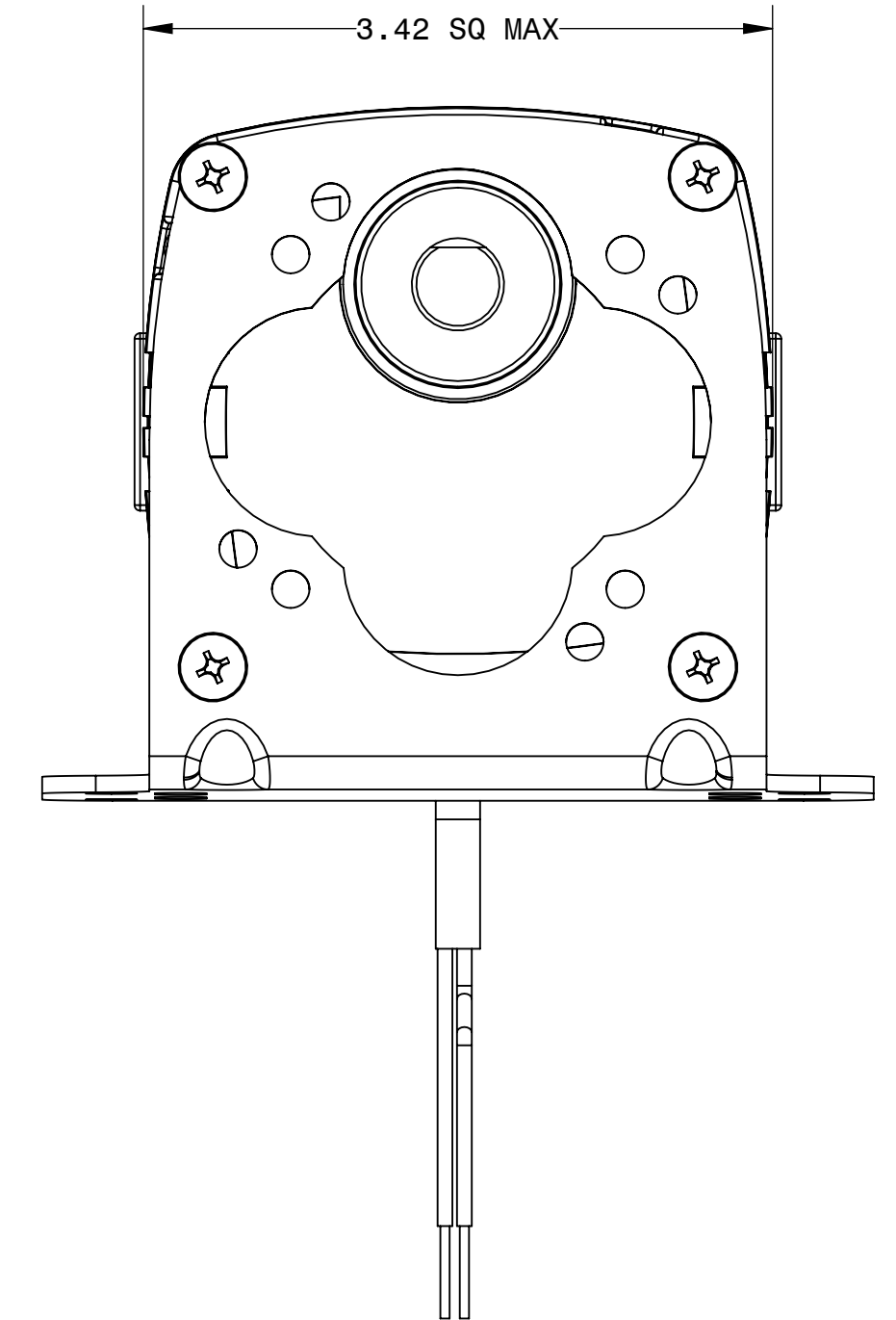
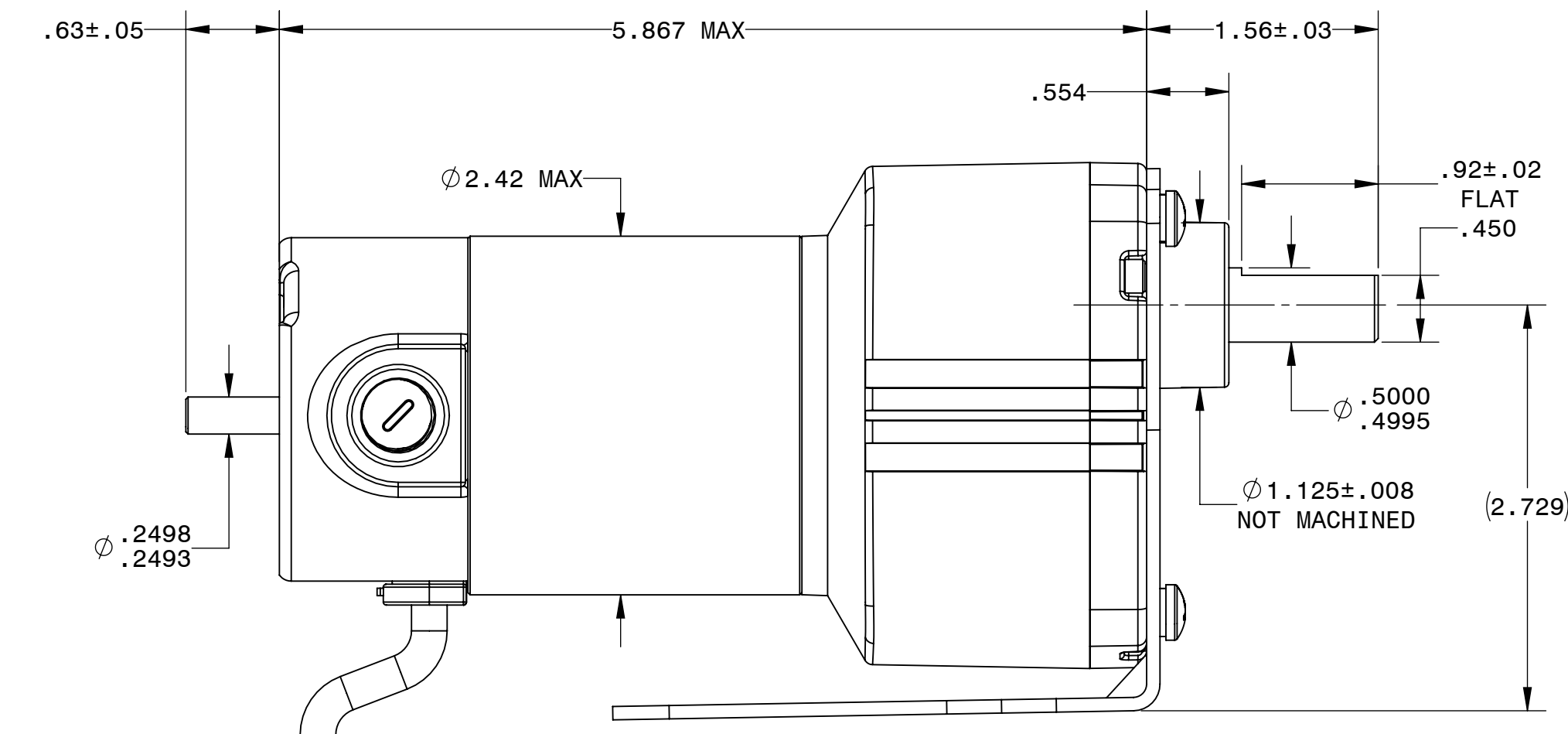
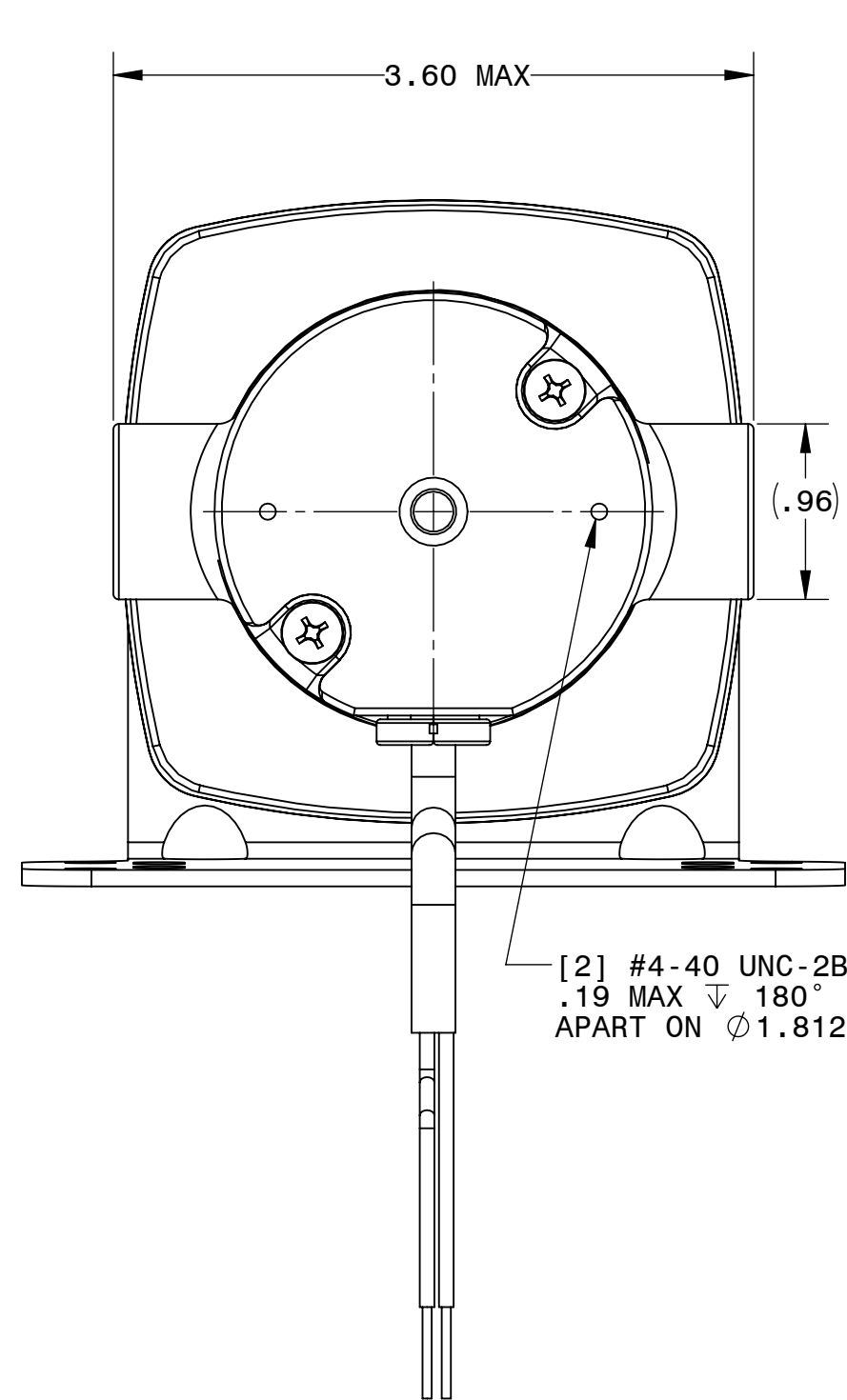

REPRESENTATIVE OF MODEL NUMBER(S): [WITH OPTIONAL BRACKET MODEL 5968]  
4491 4492 4493 4494 4495 4496 4497 4498 4499 4991 4992 4993 4994 4995 4996 4997 4998 4999